

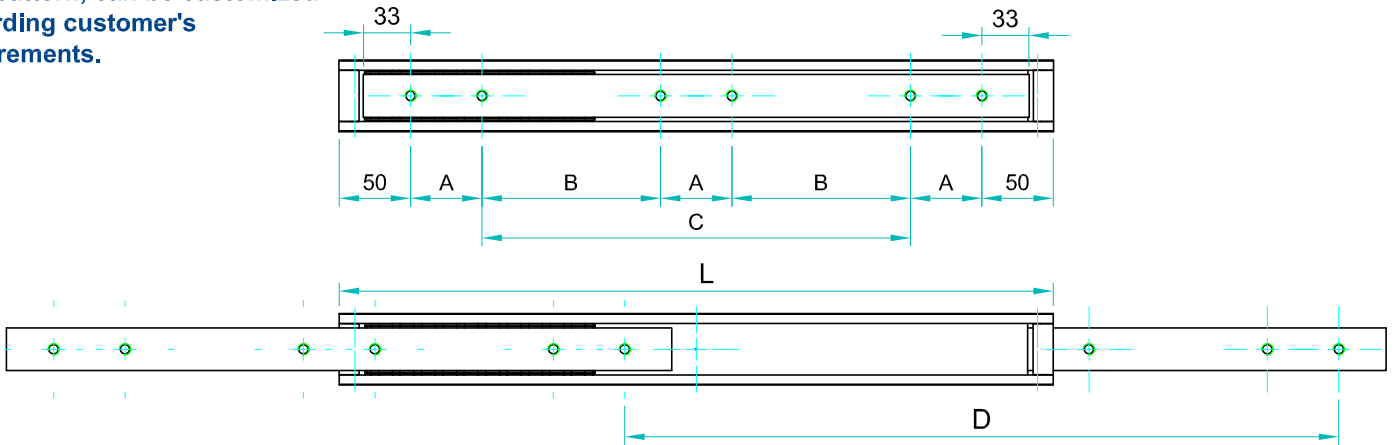

Bi directional

Slide type: **ADTSB**

Note: The slide opening and the hole pattern, can be customized according customer's requirements.



Options:

- "V" - V shape channel raceways
- "F" - one outer beam countersunk
- "FF"- both outer beams countersunk

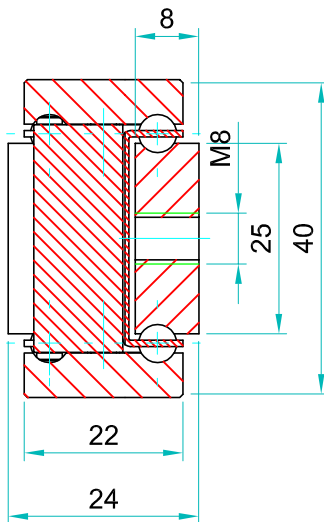

We recommend use the major axis.
Do not dismantle the slide !
The maximum safe load is given for a fully extended pair of slides, mounted on the major axis with a load spread uniformly along the inner beam
Flat mounted slide load capacities are reduced between 60-80%

Type: ADTSB-40			Hole pattern			
Article number	Instalacion lenght: L	Extension lenght: D	Load per pair: kg	"A"	"B"	"C"
ADTSB4024.0200	200	200	85	50	-	-
ADTSB4024.0250	250	250	90	50	-	50
ADTSB4024.0300	300	300	95	50	-	100
ADTSB4024.0350	350	350	100	50	-	150
ADTSB4024.0400	400	400	105	50	-	200
ADTSB4024.0450	450	450	110	50	-	250
ADTSB4024.0500	500	500	115	50	-	300
ADTSB4024.0550	550	550	120	50	150	-
ADTSB4024.0600	600	600	125	50	175	-
ADTSB4024.0650	650	650	120	50	200	-
ADTSB4024.0700	700	700	115	50	225	-
ADTSB4024.0750	750	750	110	50	250	-
ADTSB4024.0800	800	800	105	50	275	-
ADTSB4024.0850	850	850	100	50	300	-
ADTSB4024.0900	900	900	95	50	325	-
ADTSB4024.0950	950	950	90	50	350	-
ADTSB4024.1000	1000	1000	85	50	375	-
ADTSB4024.1050	1050	1050	80	50	400	-
ADTSB4024.1100	1100	1100	75	50	425	-
ADTSB4024.1150	1150	1150	70	50	450	-
ADTSB4024.1200	1200	1200	65	50	475	-
ADTSB4024.1250	1250	1250	60	50	500	-
ADTSB4024.1300	1300	1300	55	50	525	-
ADTSB4024.1350	1350	1350	50	50	550	-
ADTSB4024.1400	1400	1400	45	50	575	-
ADTSB4024.1450	1450	1450	40	50	600	-
ADTSB4024.1500	1500	1500	35	50	625	-

Material:

Beams: EN-AW 6082 T6, anodized acc. BS1615 AA10

Ball cages: 304 stainless sheet steel .

Ball bearings: 316 L

End Bolts: A2

Maximum temperature: We recommend -40 to +200°C with low/high-temp lubrication and free movement to allow for steel expansion.



Note: The slide opening and the hole pattern, can be customized according customer's requirements.

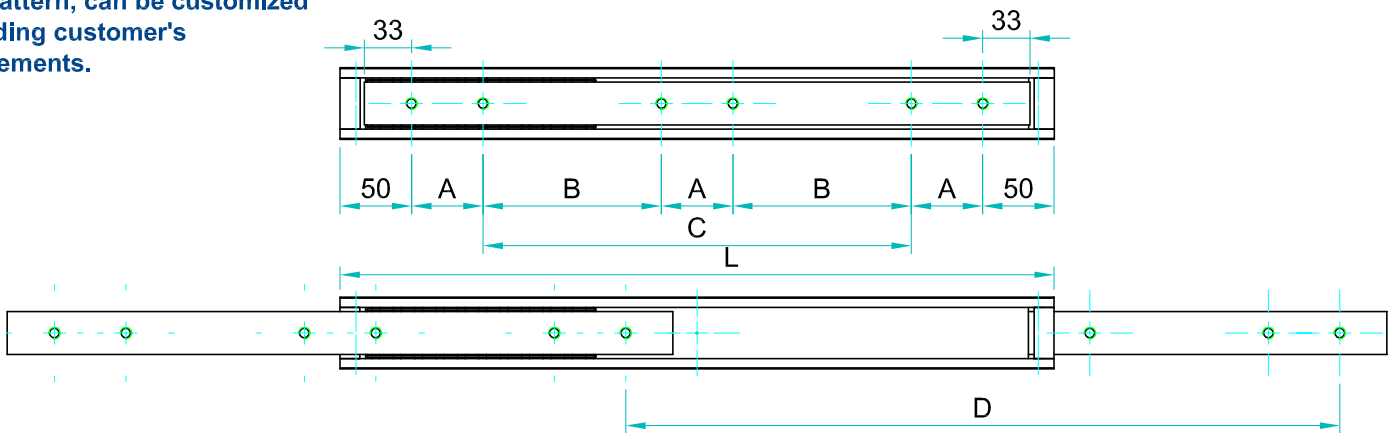

Options:

- "V" - V shape channel raceways
- "F" - one outer beam countersunk
- "FF"- both outer beams countersunk

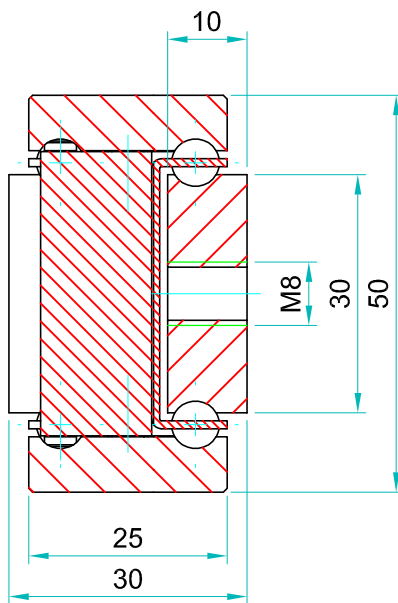

We recommend use the major axis.
Do not dismantle the slide !
The maximum safe load is given for a fully extended pair of slides, mounted on the major axis with a load spread uniformly along the inner beam
Flat mounted slide load capacities are reduced between 60-80%

Type: ADTSB-50				Hole pattern		
Article number	Instalacion lenght: L	Extension lenght: D	Load per pair: kg	"A"	"B"	"C"
ADTSB5030.0200	200	200	110	50	-	-
ADTSB5030.0250	250	250	120	50	-	50
ADTSB5030.0300	300	300	130	50	-	100
ADTSB5030.0350	350	350	140	50	-	150
ADTSB5030.0400	400	400	150	50	-	200
ADTSB5030.0450	450	450	160	50	-	250
ADTSB5030.0500	500	500	170	50	-	300
ADTSB5030.0550	550	550	180	50	150	-
ADTSB5030.0600	600	600	175	50	175	-
ADTSB5030.0650	650	650	170	50	200	-
ADTSB5030.0700	700	700	165	50	225	-
ADTSB5030.0750	750	750	160	50	250	-
ADTSB5030.0800	800	800	155	50	275	-
ADTSB5030.0850	850	850	150	50	300	-
ADTSB5030.0900	900	900	145	50	325	-
ADTSB5030.0950	950	950	140	50	350	-
ADTSB5030.1000	1000	1000	135	50	375	-
ADTSB5030.1050	1050	1050	130	50	400	-
ADTSB5030.1100	1100	1100	125	50	425	-
ADTSB5030.1150	1150	1150	120	50	450	-
ADTSB5030.1200	1200	1200	115	50	475	-
ADTSB5030.1250	1250	1250	108	50	500	-
ADTSB5030.1300	1300	1300	100	50	525	-
ADTSB5030.1350	1350	1350	92	50	550	-
ADTSB5030.1400	1400	1400	84	50	575	-
ADTSB5030.1450	1450	1450	76	50	600	-
ADTSB5030.1500	1500	1500	66	50	625	-
ADTSB5030.1550	1550	1550	55	50	650	-
ADTSB5030.1600	1600	1600	45	50	675	-

Material:

Beams: EN-AW 6082 T6, anodized acc. BS1615 AA10

Ball cages: 304 stainless sheet steel .

Ball bearings: 316 L

End Bolts: A2

Maximum temperature: We recommend -40 to +200°C with

low/high-temp lubrication and free movement to allow for steel expansion.



hole pattern, can be customized according customer's requirements.

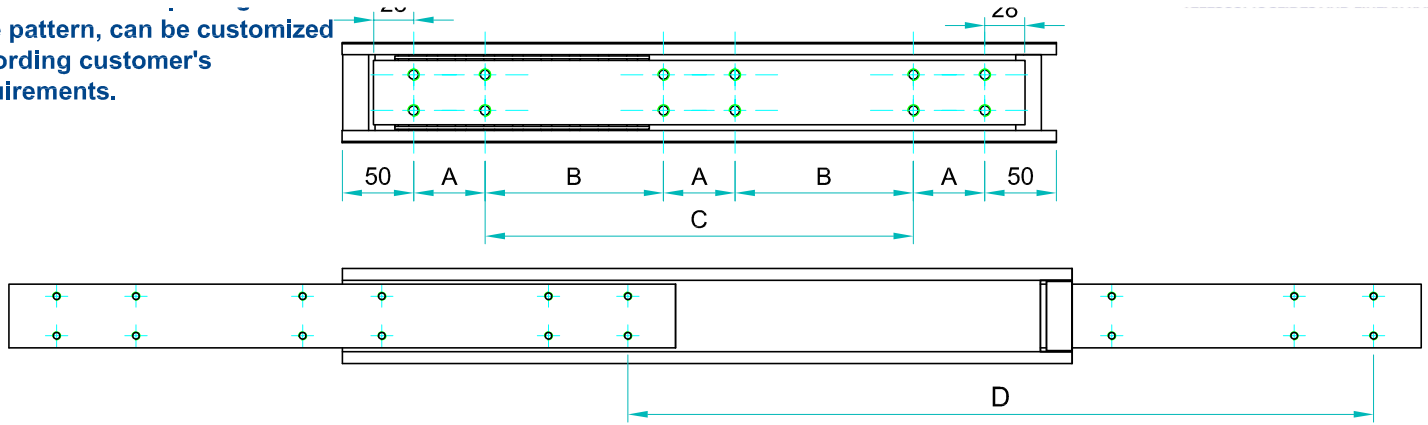

Options:
"V" - V shape channel raceways
"F" - one outer beam countersunk
"FF" - both outer beams countersunk

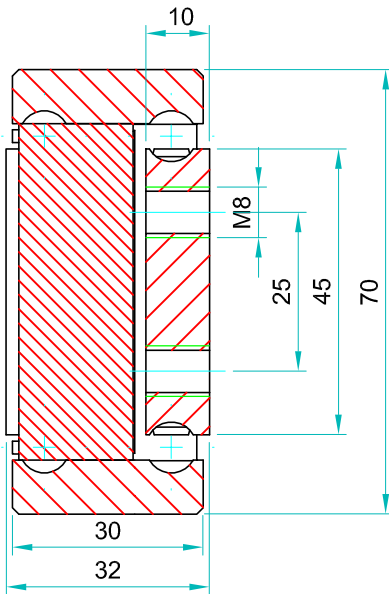

We recommend use the major axis.
 Do not dismantle the slide !
 The maximum safe load is given for a fully extended pair of slides, mounted on the major axis with a load spread uniformly along the inner beam
 Flat mounted slide load capacities are reduced between 60-80%

Type:ADTSB-70				Hole pattern		
Article number	Instalacion lenght:L	Extension lenght:D	Load per pair: kg	"A"	"B"	"C"
ADTSB7032.0200	200	200	240	50	-	-
ADTSB7032.0250	250	250	250	50	-	50
ADTSB7032.0300	300	300	260	50	-	100
ADTSB7032.0350	350	350	270	50	-	150
ADTSB7032.0400	400	400	280	50	-	200
ADTSB7032.0450	450	450	290	50	-	250
ADTSB7032.0500	500	500	300	50	-	300
ADTSB7032.0550	550	550	315	50	-	350
ADTSB7032.0600	600	600	330	50	-	400
ADTSB7032.0650	650	650	320	50	200	-
ADTSB7032.0700	700	700	310	50	225	-
ADTSB7032.0750	750	750	300	50	250	-
ADTSB7032.0800	800	800	290	50	275	-
ADTSB7032.0850	850	850	280	50	300	-
ADTSB7032.0900	900	900	270	50	325	-
ADTSB7032.0950	950	950	260	50	350	-
ADTSB7032.1000	1000	1000	250	50	375	-
ADTSB7032.1050	1050	1050	240	50	400	-
ADTSB7032.1100	1100	1100	230	50	425	-
ADTSB7032.1150	1150	1150	220	50	450	-
ADTSB7032.1200	1200	1200	210	50	475	-
ADTSB7032.1250	1250	1250	200	50	500	-
ADTSB7032.1300	1300	1300	190	50	525	-
ADTSB7032.1350	1350	1350	180	50	550	-
ADTSB7032.1400	1400	1400	170	50	575	-
ADTSB7032.1450	1450	1450	160	50	600	-
ADTSB7032.1500	1500	1500	155	50	625	-
ADTSB7032.1550	1550	1550	150	50	650	-
ADTSB7032.1600	1600	1600	145	50	675	-
ADTS7032.1650	1650	1650	140	50	700	
ADTS7032.1700	1700	1700	135	100	650	
ADTS7032.1750	1750	1750	130	100	675	
ADTS7032.1800	1800	1800	125	100	700	
ADTS7032.1850	1850	1850	120	100	725	
ADTS7032.1900	1900	1900	115	100	750	
ADTS7032.1950	1950	1950	110	100	775	
ADTS7032.2000	2000	2000	105	100	800	

Material:

Beams: EN-AW 6082 T6, anodized acc. BS1615 AA10

Ball cages: 304 stainless sheet steel .

Ball bearings: 316 L

End Bolts: A2

Maximum temperature: We recommend -40 to +200°C with low/high-temp lubrication and free movement to allow for steel expansion.

