

**Options:**

- "H" – Hardened raceways
- "V" - V shape channel raceways
- "F" - one outer beam countersunk
- "SB"- stainless steel ball bearings
- "SC"- stainless steel ball cages
- "SA"- stainless steel stopping pins and bolts

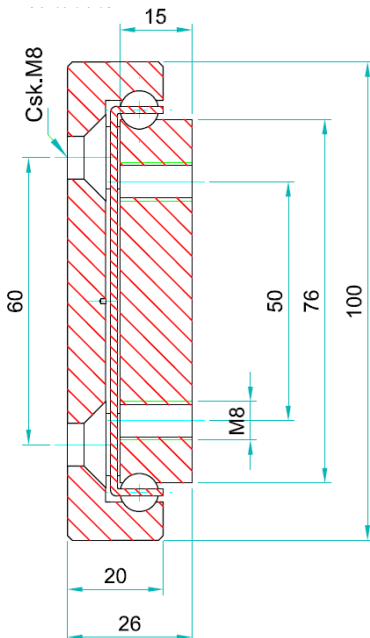

OWS-10026 weights 16.75 kg/m				Hole pattern		
Article number	Installation length: L	Extension length: D	Load per pair: kg	"A"	"B"	"C"
OWS10026.0300	300	150	1260	50	-	100
OWS10026.0350	350	175	1300	50	-	150
OWS10026.0400	400	200	1380	50	-	200
OWS10026.0450	450	225	1440	50	-	250
OWS10026.0500	500	250	1480	50	-	300
OWS10026.0550	550	275	1520	50	150	-
OWS10026.0600	600	300	1550	50	175	-
OWS10026.0650	650	325	1580	50	200	-
OWS10026.0700	700	350	1600	50	225	-
OWS10026.0750	750	375	1560	50	250	-
OWS10026.0800	800	400	1500	50	275	-
OWS10026.0850	850	425	1440	50	300	-
OWS10026.0900	900	450	1360	50	325	-
OWS10026.0950	950	475	1320	50	350	-
OWS10026.1000	1000	500	1240	50	375	-
OWS10026.1050	1050	525	1180	50	400	-
OWS10026.1100	1100	550	1100	50	425	-
OWS10026.1150	1150	575	1010	50	450	-
OWS10026.1200	1200	600	950	50	475	-



**Do not dismantle the slide!**

The maximum safe working load is stated for fully extended pair of slides, mounted upright. Use all fixing holes and spread the load evenly across the inner beam.  
 Flat mounting: Reduce the load by 60-80%.  
 We recommend the use of strong L brackets for under or floor mount.  
 Deflection is calculated up to 1% of the closed length, at or near full load capacity.

**Installation tolerance:**

Closed length Tolerance: DIN2768 – c

Extension Tolerance: DIN2768 - c

Installation width tolerance + 0.4 to – 0.6mm

OWS -10026 weights 16.75 kg/m				Hole pattern		
Article number	Installation length: L	Extension length: D	Load per pair: kg	“A”	“B”	“C”
OWS10026.1250	1250	625	900	50	500	-
OWS10026.1300	1300	650	850	50	525	-
OWS10026.1350	1350	675	810	50	550	-
OWS10026.1400	1400	700	780	50	575	-
OWS10026.1450	1450	725	730	50	600	-
OWS10026.1500	1500	750	690	50	625	-
OWS10026.1550	1550	775	650	50	650	-
OWS10026.1600	1600	800	630	50	675	-
OWS10026.1650	1650	825	610	50	700	-
OWS10026.1700	1700	850	600	100	650	-
OWS10026.1750	1750	875	590	100	675	-
OWS10026.1800	1800	900	580	100	700	-
OWS10026.1850	1850	925	565	100	725	-
OWS10026.1900	1900	950	545	100	750	-
OWS10026.1950	1950	975	525	100	775	-
OWS10026.2000	2000	1000	510	100	800	-

**Indirect Axis (Flat) Mounting:** As in the image above, reduce the load capacity by 60-80% and allow for increased deflection, or contact our engineers to request accurate FEA load analysis for OEM projects. We load rate per fully extended pair of slides on the direct axis, upright, with uniform loading across the beams, spaced 1,000mm apart. If load capacities need to be increased, or slides are fitted to extra-wide drawers, please contact us for technical advice.

**Hardened Raceways Option:** Via an accurate laser process, the raceways can be hardened to 58-62HRC without increasing production lead-times. This maximizes tensile strength, reduces friction coefficient, minimizes operational forces and substantially increases the life cycles. Load capacities for lengths under 700mm are marginally increased. Recommended operating speeds increase to 0.6m/s. A non-hardened Professional Range steel slide can be expected to achieve 100,000 cycles at 75% load capacity in a lifetime, following correct mounting, operational speeds, working environment and regular raceway cleaning with a re-lubrication schedule. (Download the Technical Maintenance Document for further information). Hardening raceways to achieve 58-62HRC and replicating the chromed steel ball bearings, results in substantially less wear and prolonged service life. Following the same maintenance schedule and operational conditions, lifespan can be anticipated to surpass 500,000 cycles. Our engineers can support OEM design programs with FEA analysis; however, we recommend in situ testing within the fabrication before committing to production.

**Material:** All steel parts.

**Beams:** Cold drawn carbon steel C45E+C, - EN 10277, milled raceways.

**Ball cages:** Zinc plated sheet steel. Laser cut profiles.

**Ball bearings:** C85, G100: DIN 5401 (Chromed).

**End Bolts:** ASTM A307.

**Steel surface protection:** Electrolytic alkaline zinc coating (10-12 microns). conforming to DIN EN ISO 9227 neutral salt spray testing. No white rust appearance within 250 hours. No red rust appearance within 1,100 hours

**Temperature range:** Steel slides –20°C to +250°C provided the necessary lubricants are applied and the beams are mounted freely to allow expansion

**Lubrication:** We apply and recommend lithium based EP3 grease for general applications. High & low temp grease upon request

**Clean Room Requirement:** The slides will be supplied unlubricated for the customer to sterilize and apply specialist grease after production

**Thread pitches:** As per end profile image - coarse

